

TABLE OF DIMENSIONS

TYPE	A	B	C	D-C-C-W	E-C-C-W	F
PA 76	3'-4"	8"	8"	PA AT 12"	PA AT 12"	A-10"
C-4, C-4S	4'-0"	8"	8"	PA AT 12"	PA AT 12"	B-10"
C-8	4'-0"	8"	8"	PA AT 12"	PA AT 12"	C-10"
C-12	4'-0"	8"	8"	PA AT 12"	PA AT 12"	D-10"
C-16	4'-0"	8"	8"	PA AT 12"	PA AT 12"	E-10"
C-20	4'-0"	8"	8"	PA AT 12"	PA AT 12"	F-10"
C-24	4'-0"	8"	8"	PA AT 12"	PA AT 12"	G-10"
C-28	4'-0"	8"	8"	PA AT 12"	PA AT 12"	H-10"
C-32	4'-0"	8"	8"	PA AT 12"	PA AT 12"	I-10"

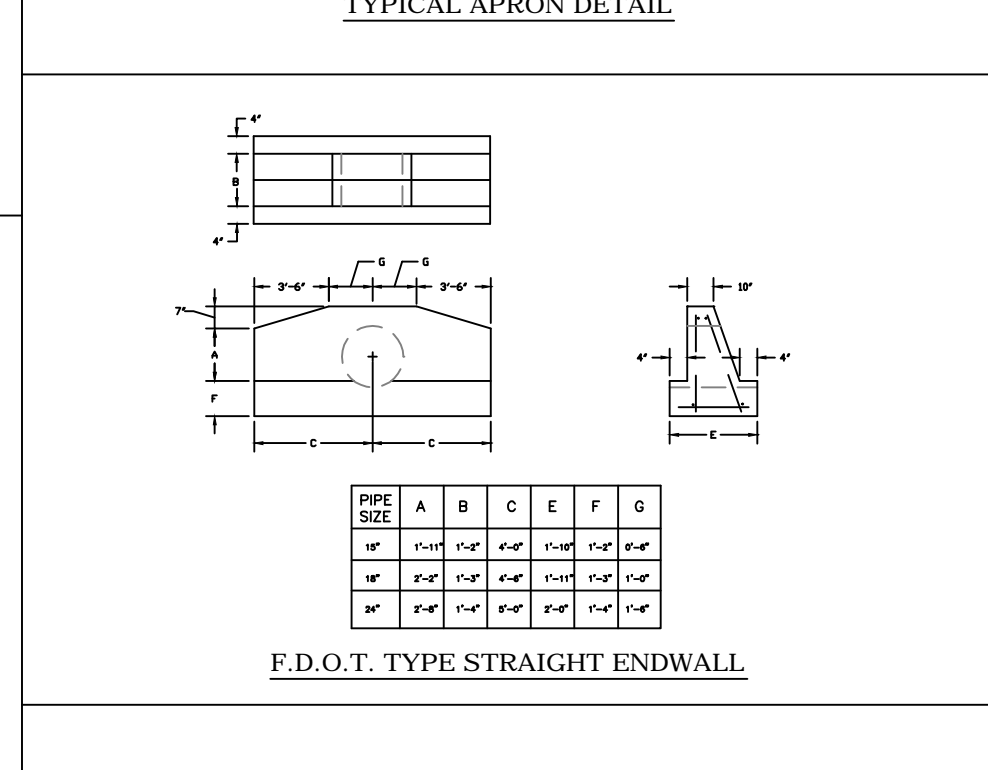
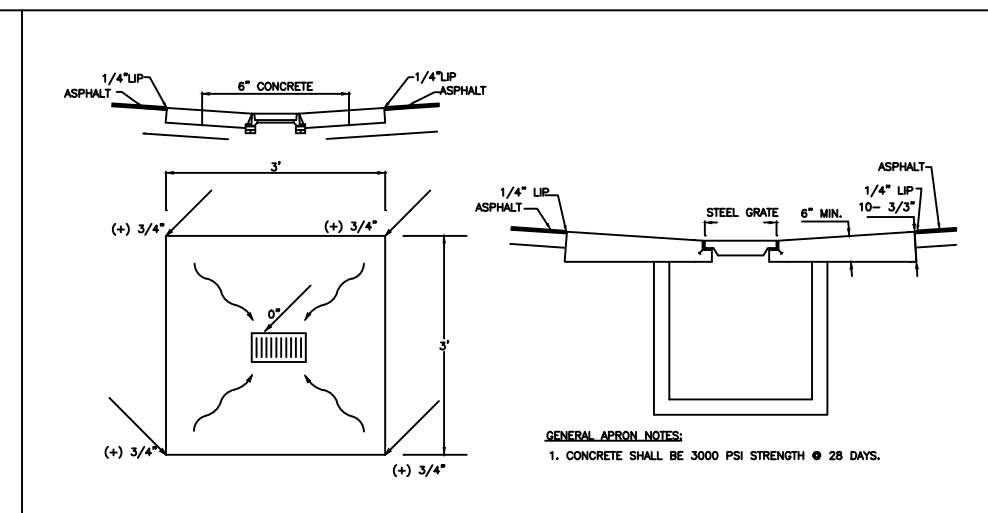
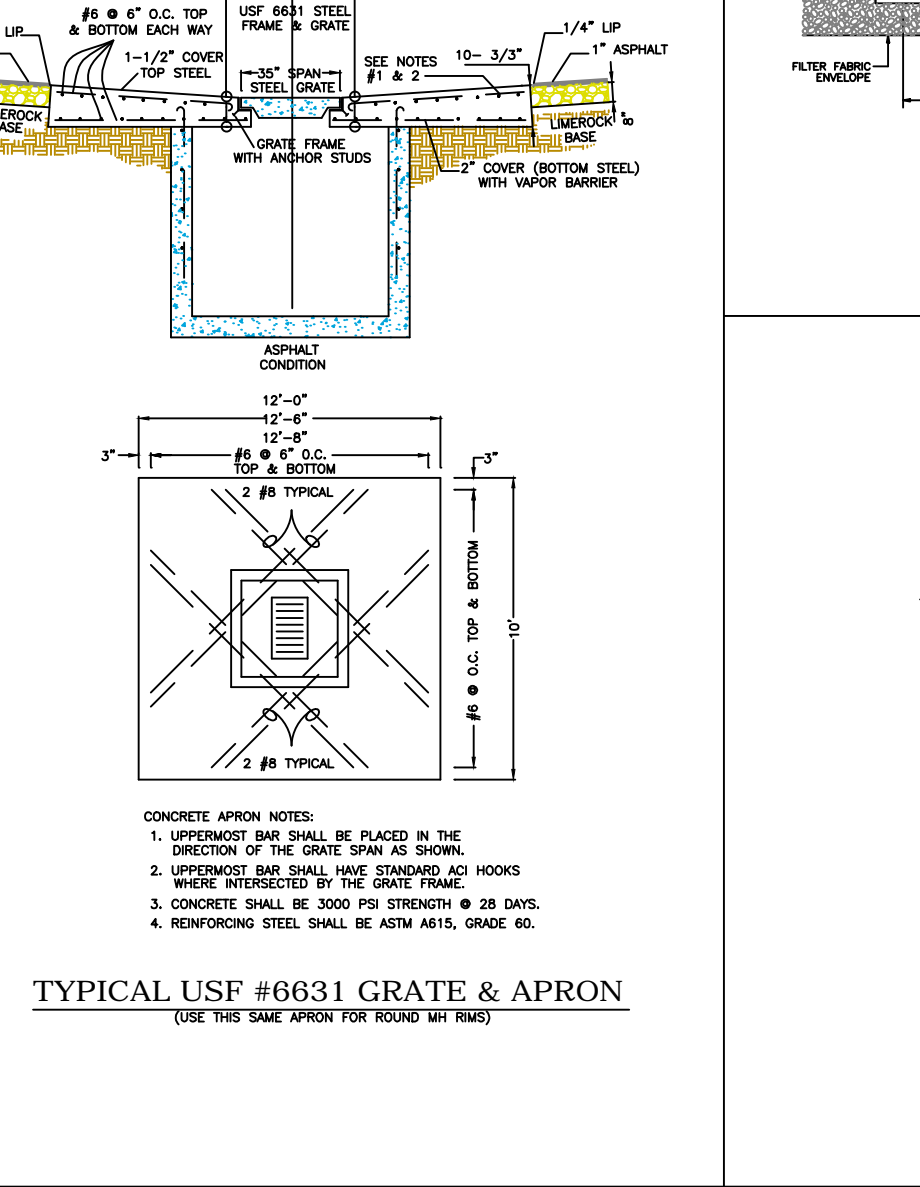
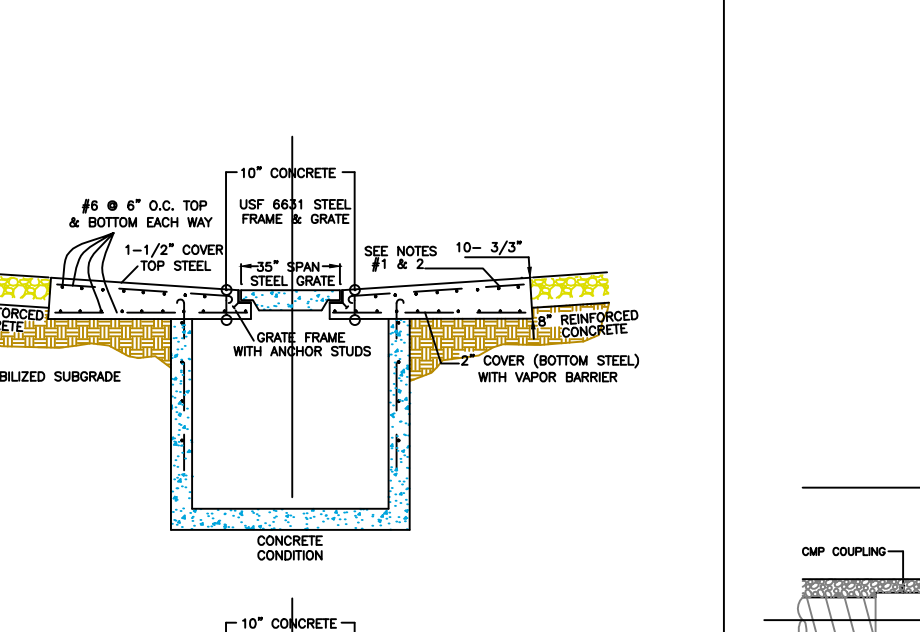
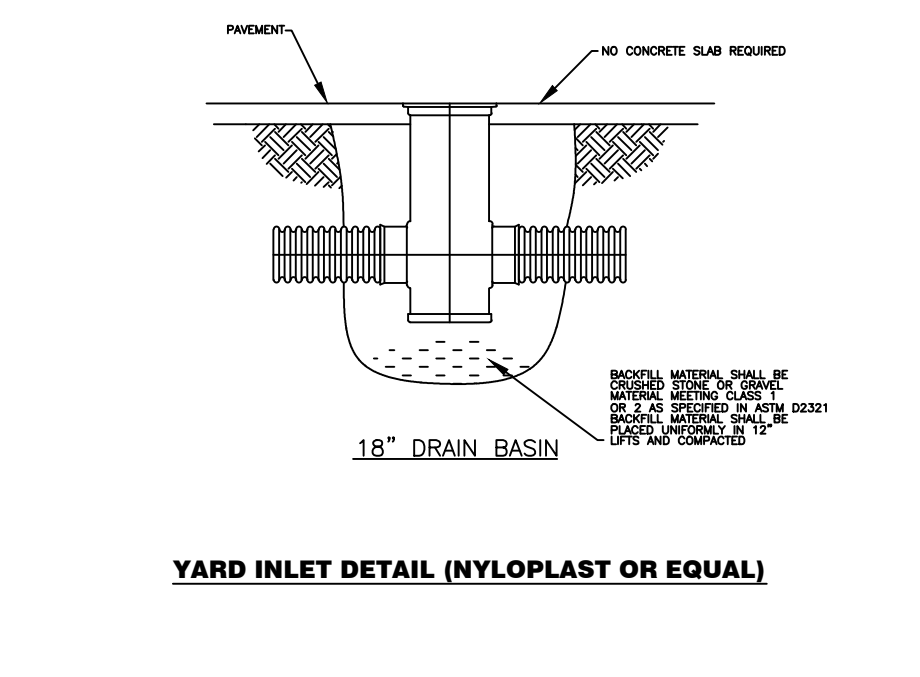
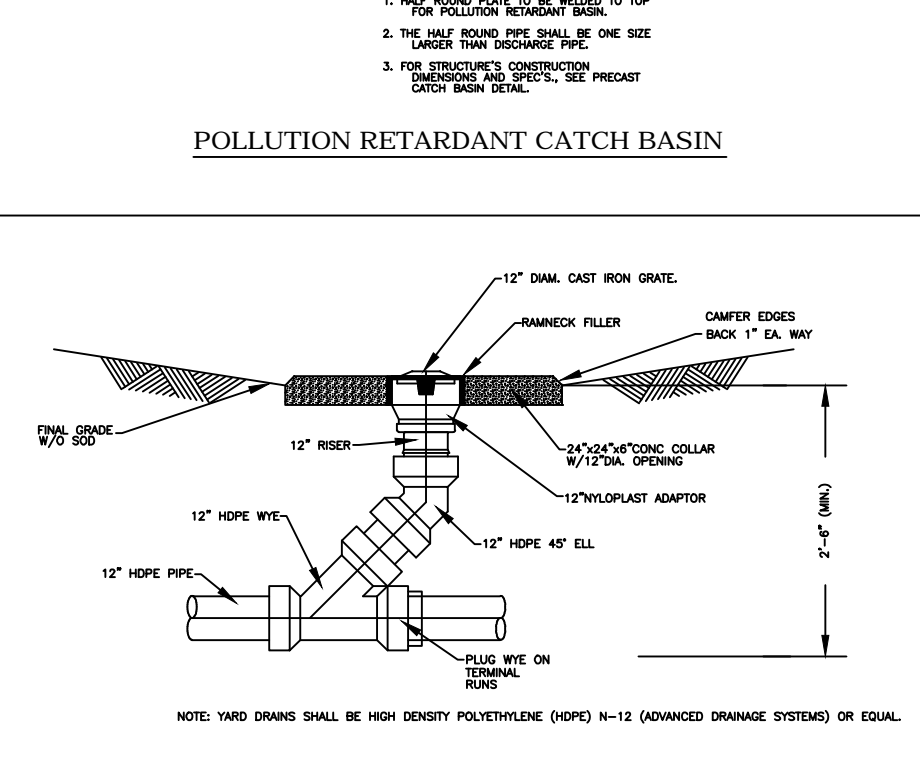
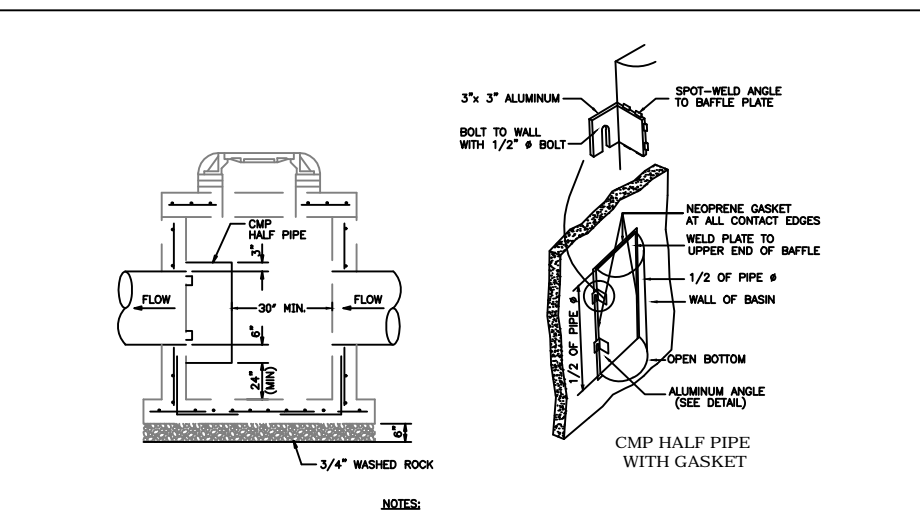
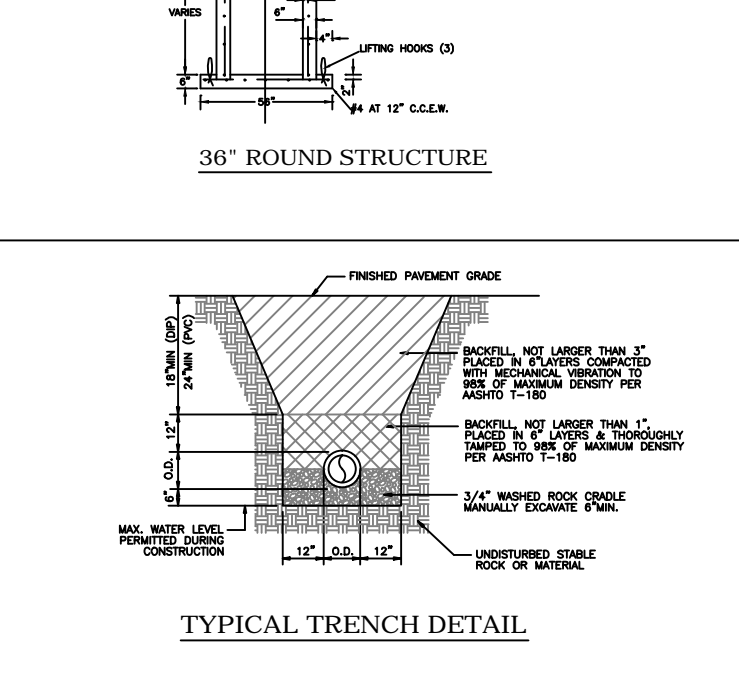
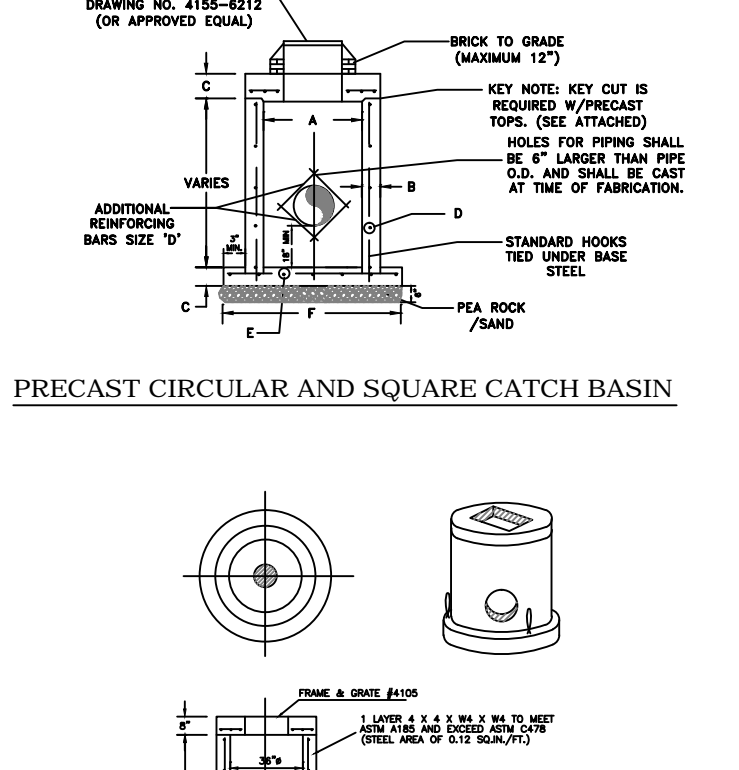
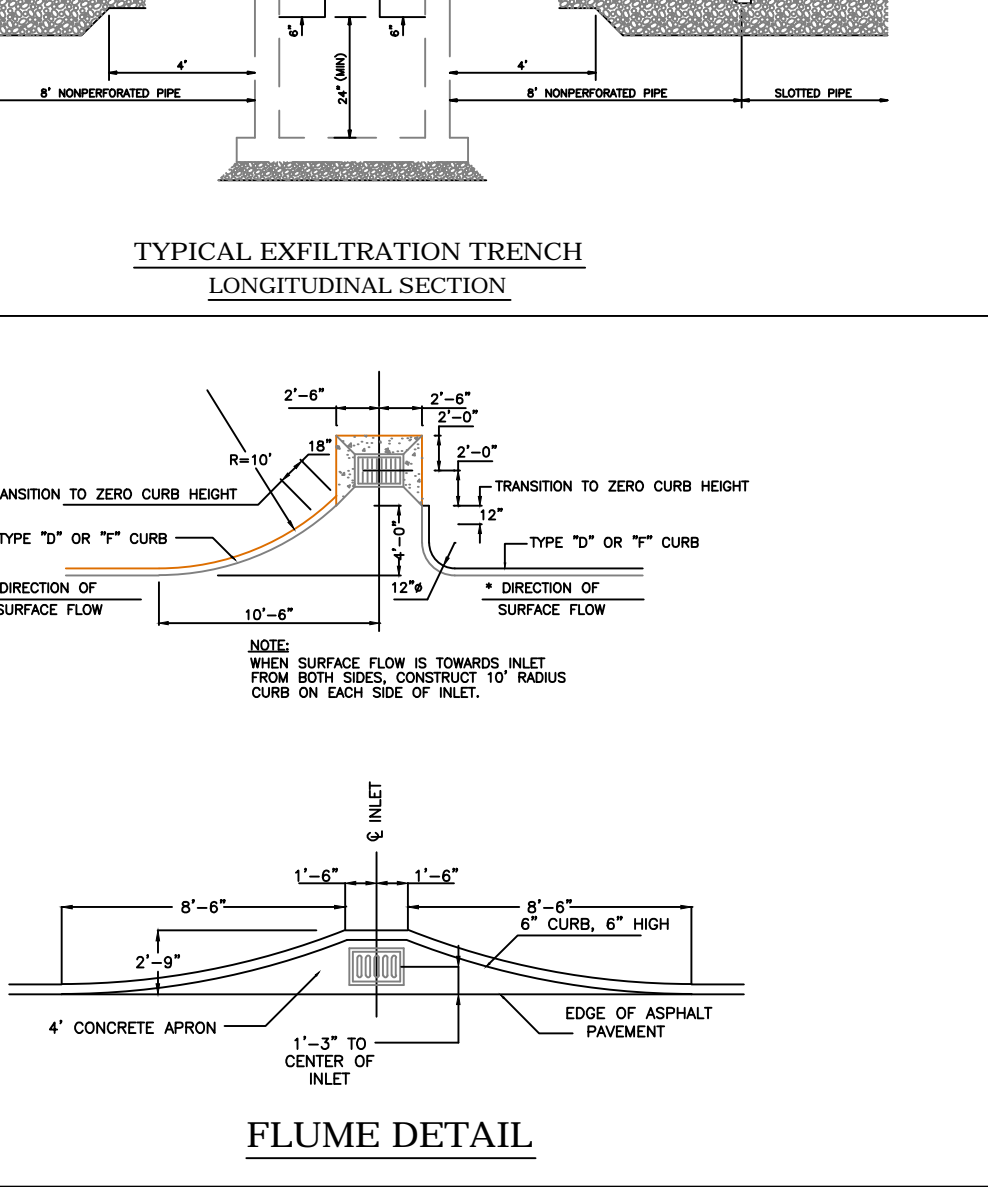
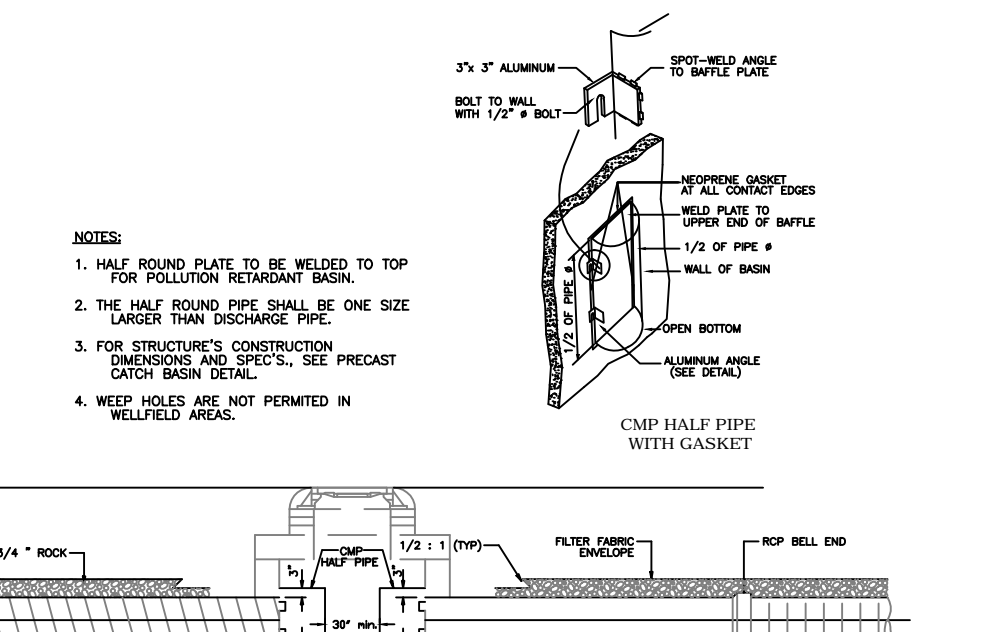
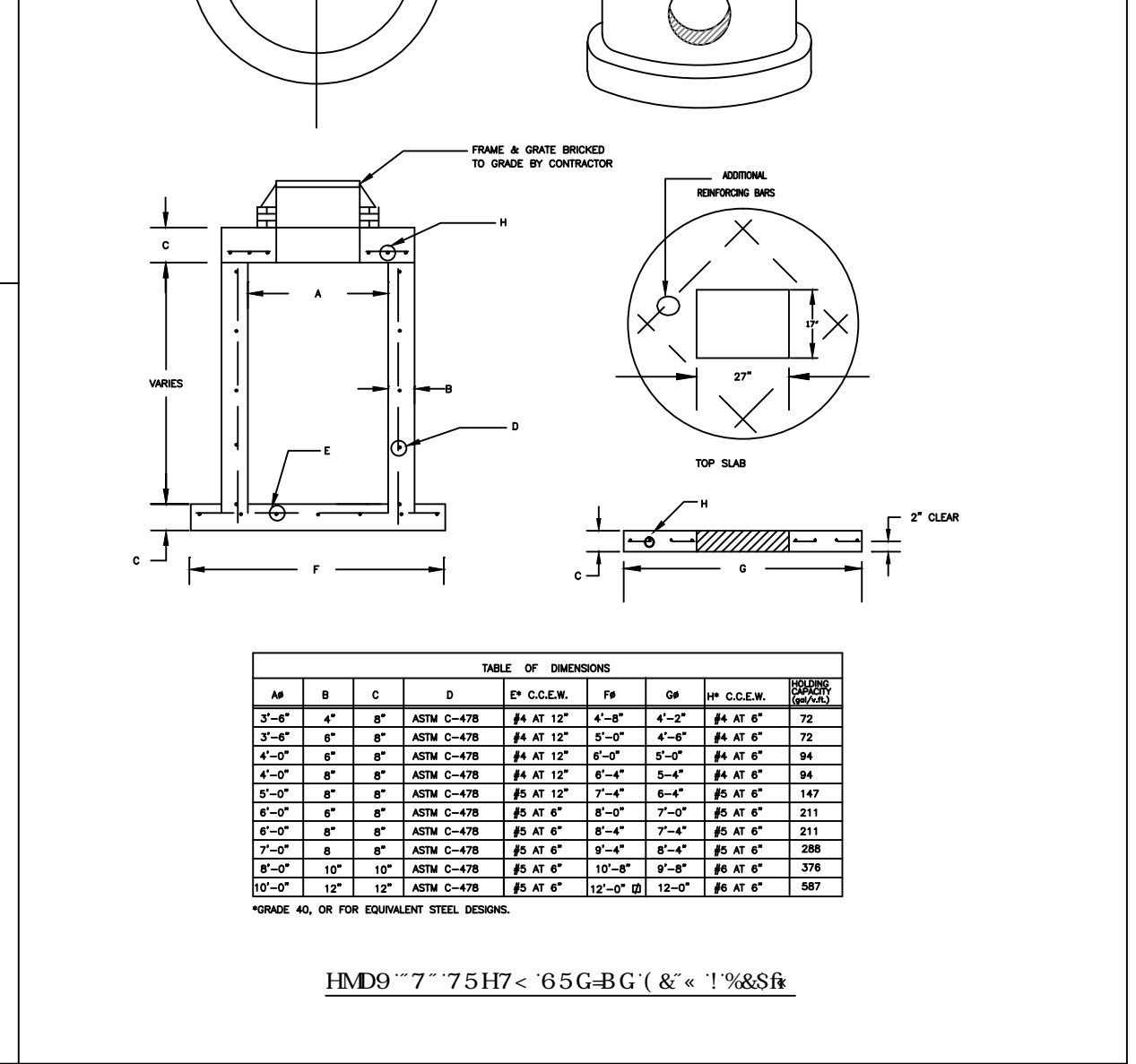
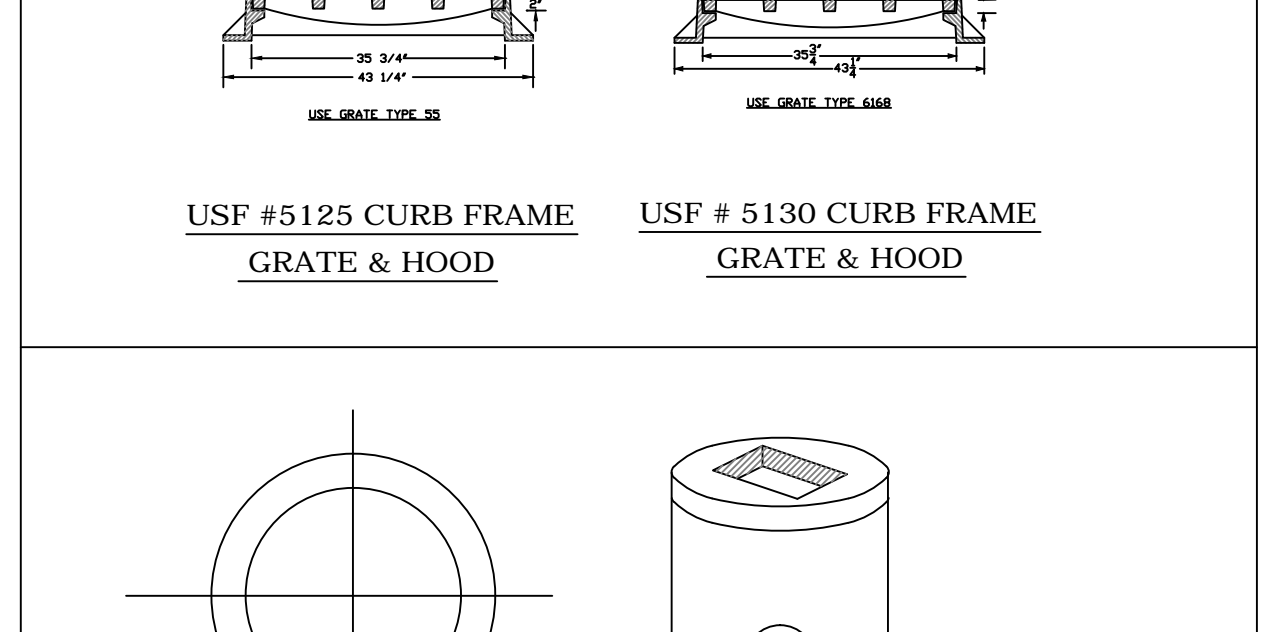
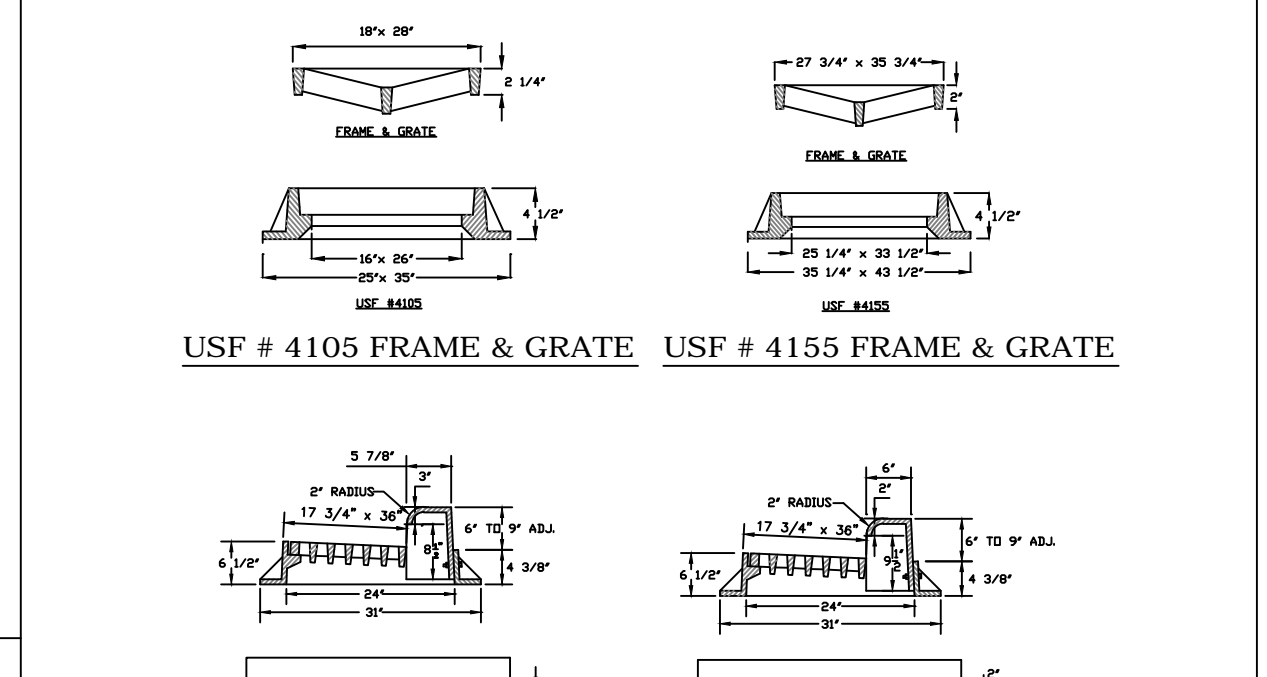
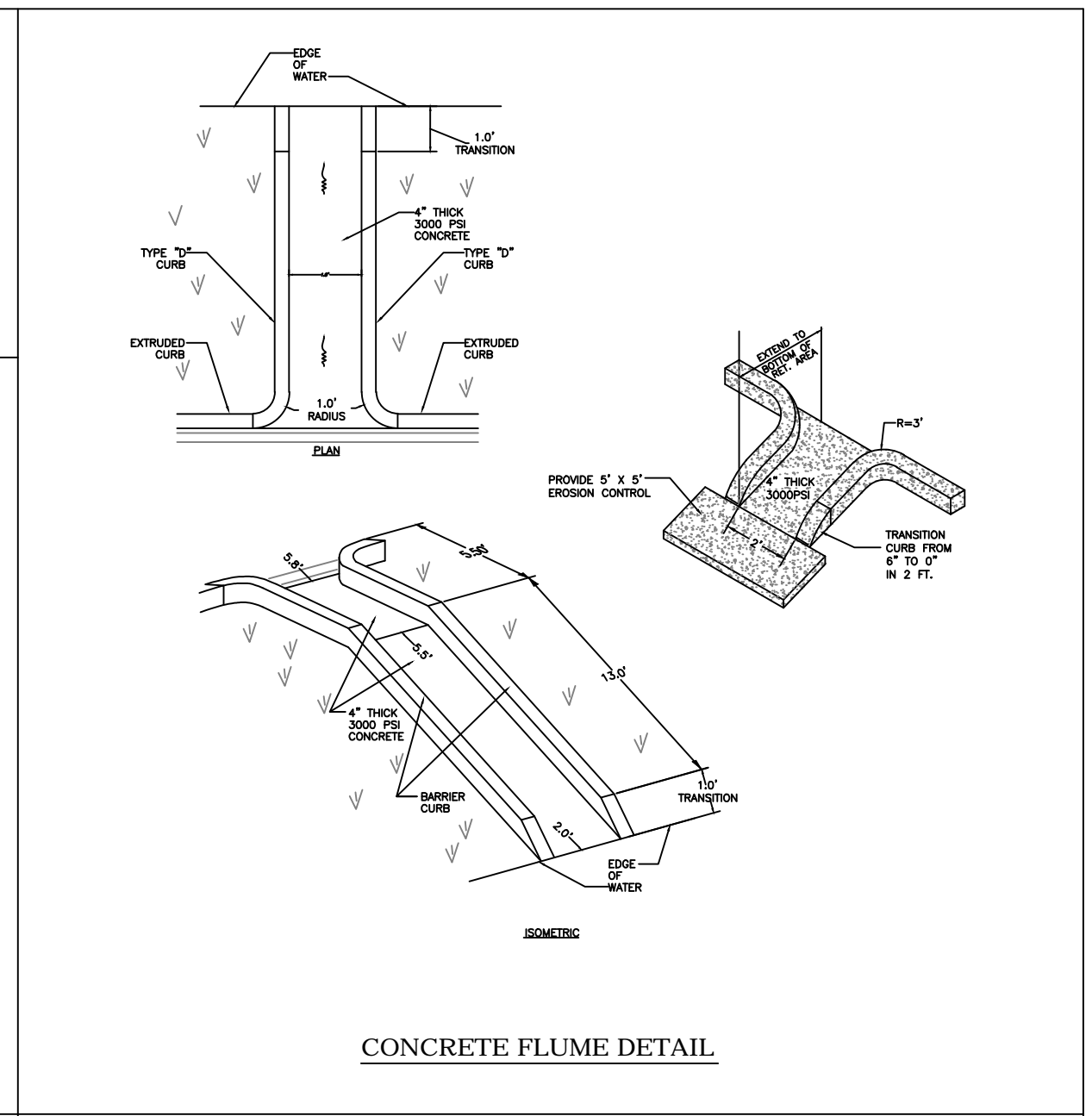
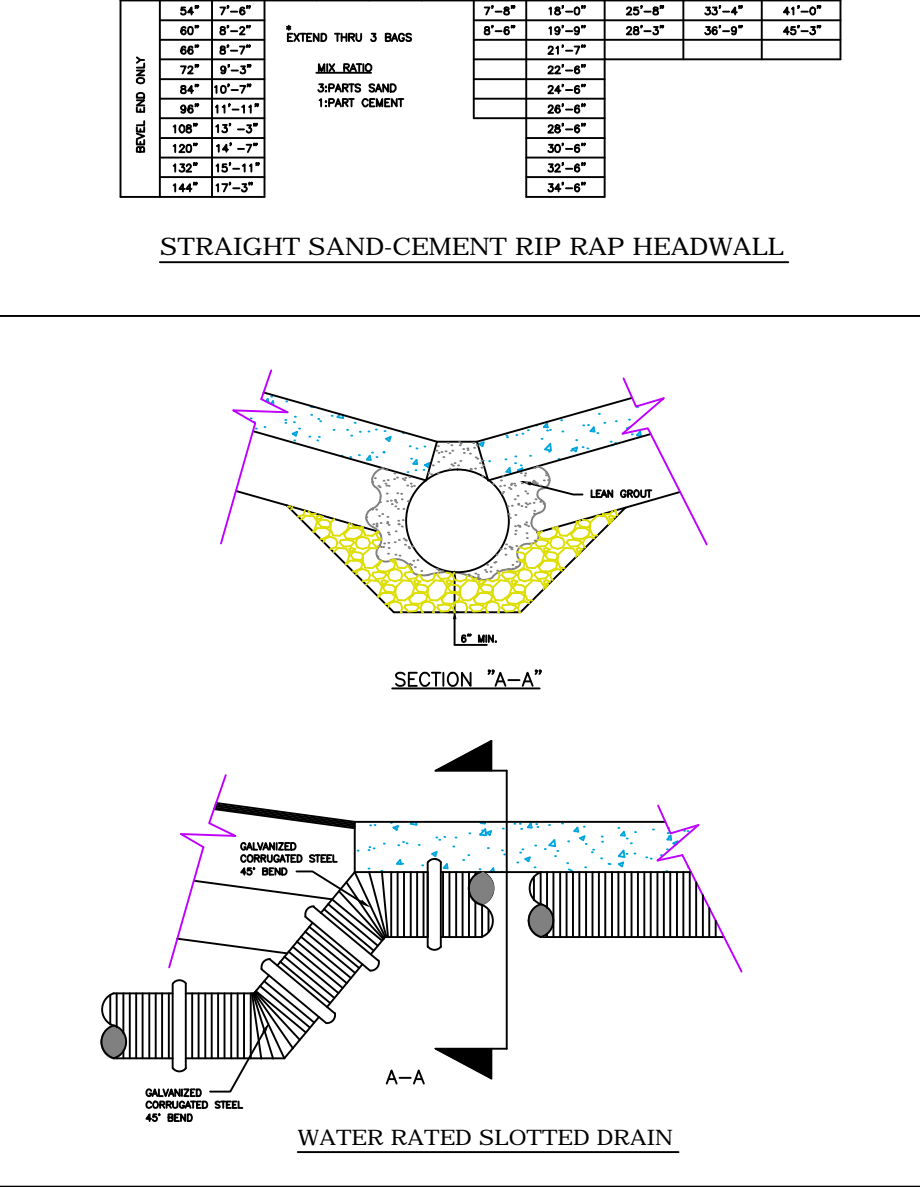
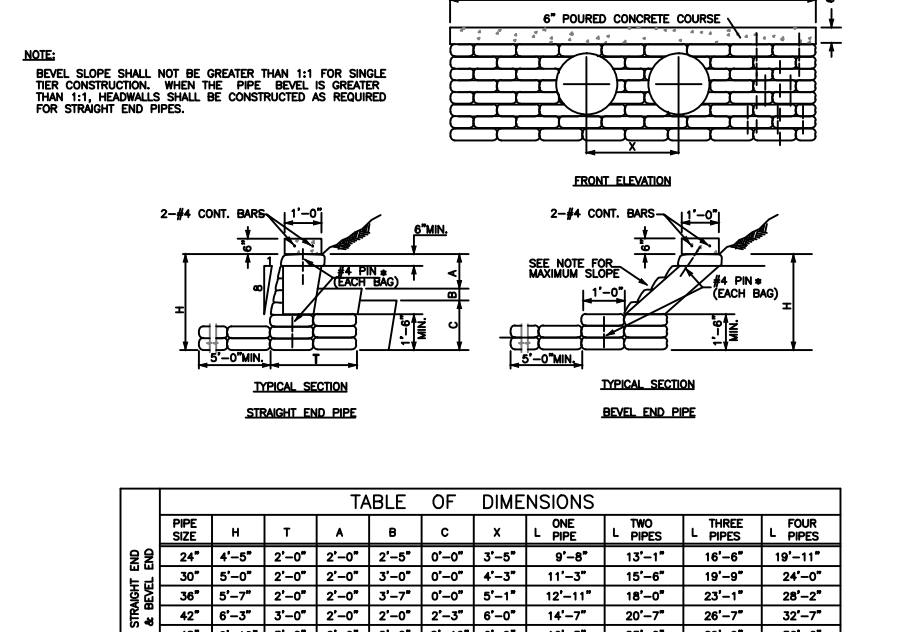
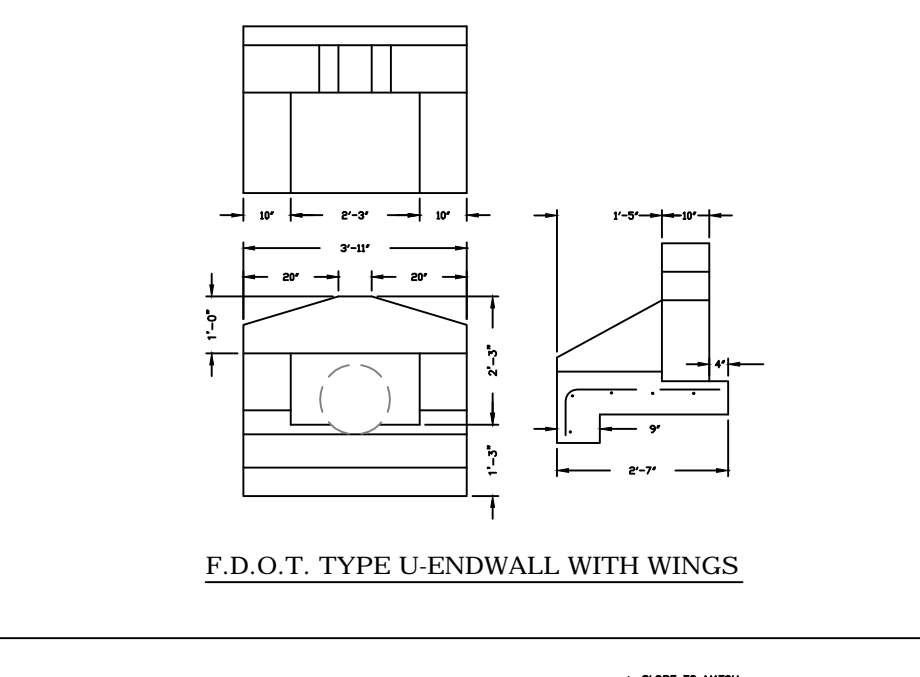
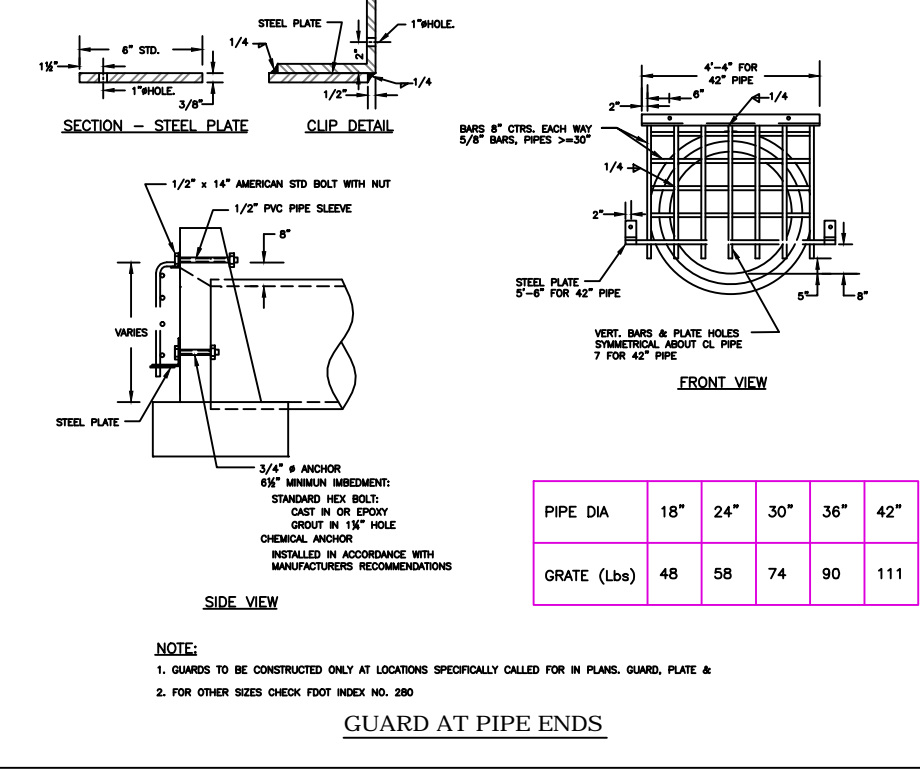

TABLE OF DIMENSIONS AND ESTIMATE QUANTITIES FOR CULVERTS IN ONE ENDWALL

DIAMETER	LENGTH	CONCRETE	STEEL	GRATE
12"	10'	1.00	0.00	0.00
18"	10'	1.50	0.00	0.00
24"	10'	2.00	0.00	0.00
30"	10'	2.50	0.00	0.00
36"	10'	3.00	0.00	0.00
42"	10'	3.50	0.00	0.00
48"	10'	4.00	0.00	0.00
54"	10'	4.50	0.00	0.00
60"	10'	5.00	0.00	0.00
66"	10'	5.50	0.00	0.00
72"	10'	6.00	0.00	0.00
78"	10'	6.50	0.00	0.00
84"	10'	7.00	0.00	0.00
90"	10'	7.50	0.00	0.00
96"	10'	8.00	0.00	0.00
102"	10'	8.50	0.00	0.00
108"	10'	9.00	0.00	0.00
114"	10'	9.50	0.00	0.00
120"	10'	10.00	0.00	0.00



NOTE:
THE DETAILS PROVIDED ON THIS SHEET ARE NOT UNDER ANY CIRCUMSTANCES TO BE MODIFIED OR ALTERED. THE ENGINEER OF RECORD, CONTRACTOR AND/OR DEVELOPER SHALL ADHERE TO THE SPECIFICATIONS DESCRIBED HEREIN. IN CASE OF A DISCREPANCY, THE DETAILS SHOWN HEREIN SHALL SUPERSEDE.



REVISIONS			REVISIONS		
No.	Date	Remarks	No.	Date	Remarks

Design By: _____ Date: 10/01/2006
 Drawn By: C.D.L. Date: 10/01/2006
 Checked By: J.E.D. Date: 10/01/2006
 Approved By: _____ Date: 10/01/2006

CITY OF TAMARAC
 PUBLIC WORKS DEPARTMENT
 ENGINEERING DIVISION

Seal: _____
 JOHN DOHERTY, P.E.

STANDARD DRAINAGE
 DETAILS
 CITY OF TAMARAC, BROWARD COUNTY, FLORIDA

Job No. _____
 Scale: N.T.S.
 SHEET 1 OF 1